

13 12 11 10 9 8 7 6 5 4 3 2 1

J
I
H
G
F
E
D
C
B
A

J
I
H
G
F
E
D
C
B
A

NOTES:

- ASSEMBLY NO. 71233-0007 SHOWN FOR ILLUSTRATION.
- MATES WITH PART NO. 71694-****, AND 5557-**.
- SEE FOLLOWING PAGES FOR PART NOS. & CONFIGURATIONS.
- FINISHES (SEE CHART):
 TIN OVERALL - .000150/(0.0038) MINIMUM TIN OVERALL, NICKEL UNDERPLATE OVERALL.
 30 GOLD - .000030/(0.00076) MINIMUM SELECT GOLD AND .000100/(0.00254) MINIMUM SELECT TIN OVER NICKEL UNDERPLATE OVERALL.
 15 GOLD - .000015/(0.00038) MINIMUM SELECT GOLD AND .000150/(0.0038) MINIMUM SELECT TIN OVER NICKEL UNDERPLATE OVERALL.
- ITEM NO'S PRECEDED BY AN *X* IN THE CHARTS ARE NOT AVAILABLE.
- HOUSING MATERIAL: HIGH TEMP. 94V-0 GLASS FILLED POLYESTER MATERIAL COLOR: WHITE
- PIN MATERIAL: BRASS.
- PART CONFORMS TO SPECIFICATION NO. PS-71690-001.
- PACKAGING SPECIFICATIONS:
 FOR TRAY, SEE PK-71232-0000
 FOR TUBE, SEE PK-71233-0000

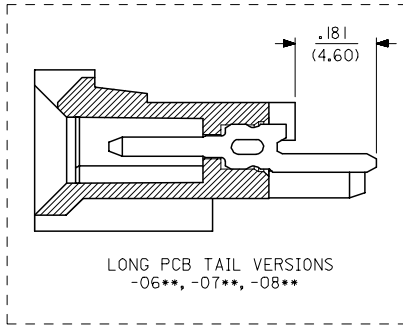
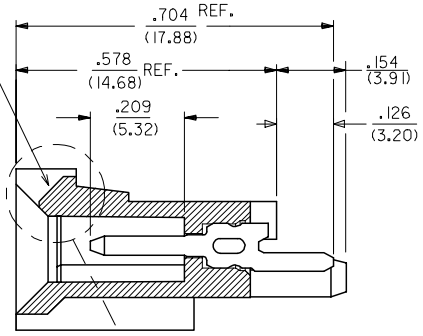
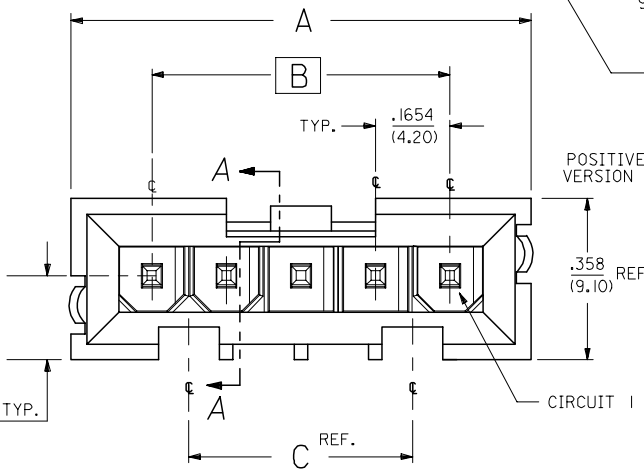
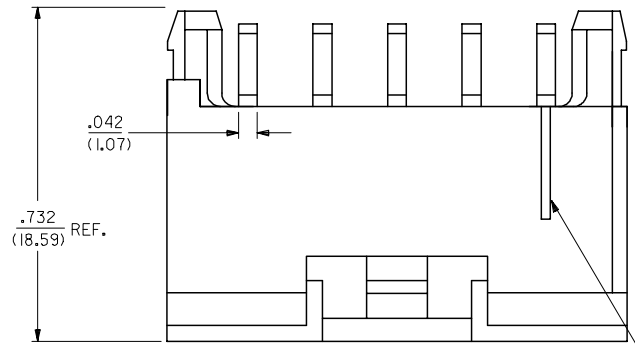
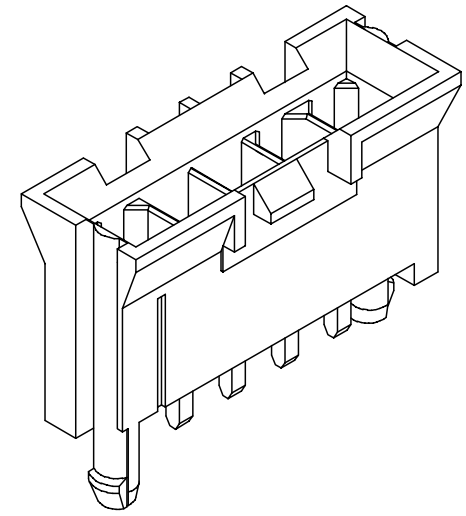

VERTICAL TAIL HOLE PATTERN

CONNECTOR SIDE SHOWN

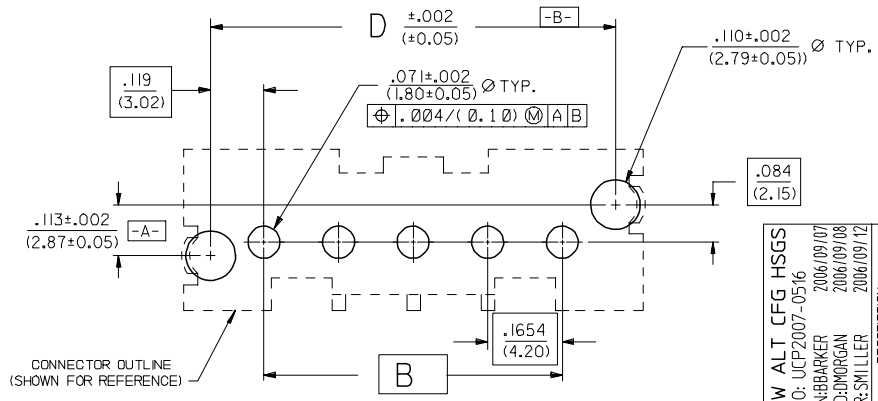

NOTE FOR LEAD FREE CONVERSION:

THE PRIMARY SHIPPING CARTON WILL BE LABELED *COMPLIANT TO ROHS DIRECTIVE 2002/95/EC AND ELV ANNEX II OF DIRECTIVE 2000/53/EC*. CARTONS WITHOUT THIS LABEL MAY CONTAIN PRODUCT WITH LEAD.

4	L
3	L
2	M
1	M

SHOW ALT CFG HSGS EC NO: UCP2007-0516 2006/09/07 DRW:NBARKER CHKD:DMORGAN APPR:SMILLER 2006/09/08 2006/09/12	QUALITY SYMBOLS ▽=0 ▽=0	GENERAL TOLERANCES (UNLESS SPECIFIED)		DIMENSION STYLE IN/MM		SCALE 5:1	DESIGN UNITS INCH	THIRD ANGLE PROJECTION			
		4 PLACES ± --- ± ---	3 PLACES ± --- ± .010	DRAWN BY RWB	DATE 7/19/93	TITLE SINGLE ROW MINI-FIT HEADER, VERTICAL, THRU-HOLE SALES DWG					
		2 PLACES ± 0.38 ± .015	1 PLACE ± 0.25 ± ---	CHECKED BY PAR	DATE 7/19/93	MATERIAL NO. SDA-71231-****					
		ANGULAR ±1/2°		APPROVED BY FAH	DATE 7/19/93	MOLEX INCORPORATED					
DRAFT WHERE APPLICABLE MUST REMAIN WITHIN DIMENSIONS		SEE TABLES		DOCUMENT NO.		SHEET NO.		1 OF 4			
THIS DRAWING CONTAINS INFORMATION THAT IS PROPRIETARY TO MOLEX INCORPORATED AND SHOULD NOT BE USED WITHOUT WRITTEN PERMISSION											

12 11 10 9 8 7 6 5 4 3 2 1

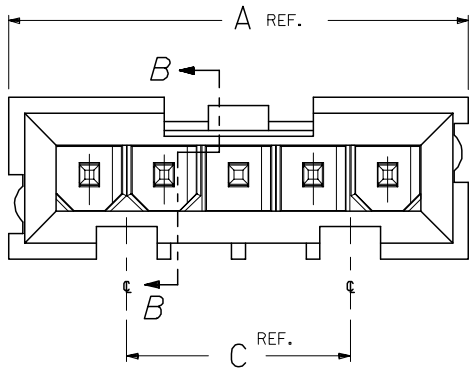

SEE SHEET 1 FOR ALL OTHER INFORMATION

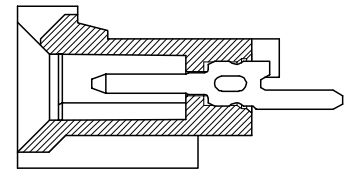

SECTION B-B

NO PEG OPTION

VERTICAL CONFIGURATIONS

OVERALL DIMENSIONS

ASSEMBLIES WITH PEGS

SIZE	DIM. "A"		DIM. "B" BASIC		DIM. "C" REF.		DIM. "D"	
	INCH	(MM)	INCH	(MM)	INCH	(MM)	INCH	(MM)
2	0.524	(13.31)	0.1654	(4.200)	N/A	N/A	.403	(10.24)
3	0.689	(17.51)	0.3307	(8.400)	N/A	N/A	.569	(14.44)
4	0.855	(21.71)	0.4961	(12.600)	0.330	(8.40)	.734	(18.64)
5	1.020	(25.91)	0.6614	(16.800)	0.496	(12.60)	.899	(22.84)
6	1.185	(30.11)	0.8268	(21.000)	0.661	(16.80)	1.064	(27.04)
7	1.351	(34.31)	0.9921	(25.200)	0.826	(21.00)	1.230	(31.24)
8	1.516	(38.51)	1.1575	(29.400)	0.992	(25.20)	1.395	(35.44)
9	1.682	(42.71)	1.3228	(33.600)	1.157	(29.40)	1.561	(39.64)
10	1.847	(46.91)	1.4882	(37.800)	1.322	(33.60)	1.726	(43.84)
11	2.012	(51.11)	1.6535	(42.000)	1.488	(37.80)	1.891	(48.04)
12	2.177	(55.31)	1.8189	(46.200)	1.653	(42.00)	2.057	(52.24)

ASSEMBLIES WITHOUT PEGS

SIZE	DIM. "A"		DIM. "B" BASIC		DIM. "C" REF.	
	INCH	(MM)	INCH	(MM)	INCH	(MM)
2	0.524	(13.31)	0.1654	(4.200)	N/A	N/A
3	0.689	(17.51)	0.3307	(8.400)	N/A	N/A
4	0.855	(21.71)	0.4961	(12.600)	0.330	(8.40)
5	1.020	(25.91)	0.6614	(16.800)	0.496	(12.60)
6	1.185	(30.11)	0.8268	(21.000)	0.661	(16.80)
7	1.351	(34.31)	0.9921	(25.200)	0.826	(21.00)
8	1.516	(38.51)	1.1575	(29.400)	0.992	(25.20)
9	1.682	(42.71)	1.3228	(33.600)	1.157	(29.40)
10	1.847	(46.91)	1.4882	(37.800)	1.322	(33.60)
11	2.012	(51.11)	1.6535	(42.000)	1.488	(37.80)
12	2.177	(55.31)	1.8189	(46.200)	1.653	(42.00)

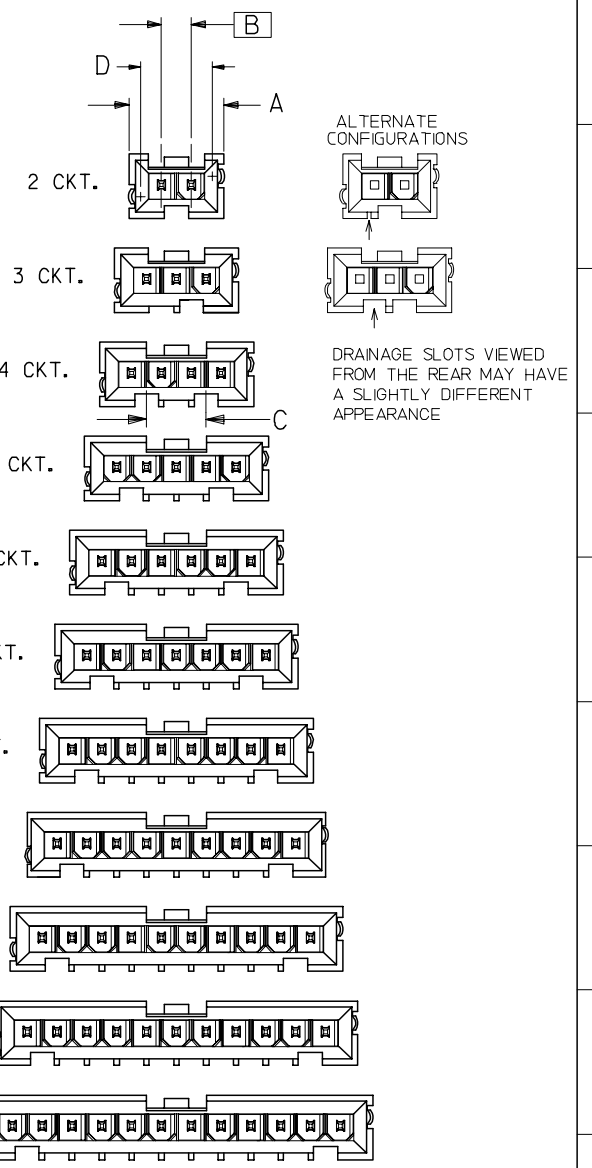

ADD ALT CONFIGS EC NO: UCP2007-0516 DRAWN: BARKER 2006/09/07 CHKD: BORGAN 2006/09/08 APPR: MILLER 2006/09/12 M	QUALITY SYMBOLS ▽=0 ▽=0	GENERAL TOLERANCES (UNLESS SPECIFIED) mm INCH 4 PLACES ± --- ± --- 3 PLACES ± --- ± .010 2 PLACES ± 0.38 ± .015 1 PLACE ± 0.25 ± --- ANGULAR ±1/2°		DIMENSION STYLE IN/MM	SCALE 5:1	DESIGN UNITS INCH	THIRD ANGLE PROJECTION		
		DRAWN BY RWB		DATE 7/19/93	SINGLE ROW MINI-FIT HEADER ASSEMBLY VERTICAL, THRU HOLE				
		CHECKED BY PAR		DATE 7/19/93	MOLEX INCORPORATED				
		APPROVED BY FAH		DATE 7/19/93	MATERIAL NO. SEE TABLES		DOCUMENT NO. SDA-71231-***	SHEET NO. 2 OF 4	
DRAFT WHERE APPLICABLE MUST REMAIN WITHIN DIMENSIONS									
THIS DRAWING CONTAINS INFORMATION THAT IS PROPRIETARY TO MOLEX INCORPORATED AND SHOULD NOT BE USED WITHOUT WRITTEN PERMISSION									

